

The Gateway
Ei1000G
Installation Manual

Read and retain carefully for as long as the product is being used. It contains vital information on the operation and installation. The manual should be regarded as part of the product.





Contents

	Page
1. Introduction	4
2. Product Overview	5
3. Technical Specifications	6
4. Important Safety Instructions	7
5. Locating your Gateway	8
6. Installation	9
7. Gateway System Set Up	11
8. Testing	11
9. Troubleshooting	12
10. Guarantee	13
11. Contact us	16

1. Introduction

An exciting innovation in home life safety, the Ei1000G Gateway will connect to compatible RF Alarms and RF devices to push data to the HomeLINK Dashboard and App for Residents.

The Ei1000G provides timely information pertinent to the type of devices installed allowing clients to view, monitor and manage their installations and support their customers.

Features include:

- Detailed property and portfolio views, designed for multiple user roles
- Actionable insights segmented by high, medium and low risk
- Dedicated HomeLINK App for Residents available
- Text alert and e-mail notification capability
- Property, Insight, Alert and Device reports

A Gateway is necessary in the system to push events from the devices to the HomeLINK Portal as they happen. The Gateway is a cellular roaming device that ensures the maximum connectivity possible without the need for local broadband or Wi-Fi services.

2. Product Overview

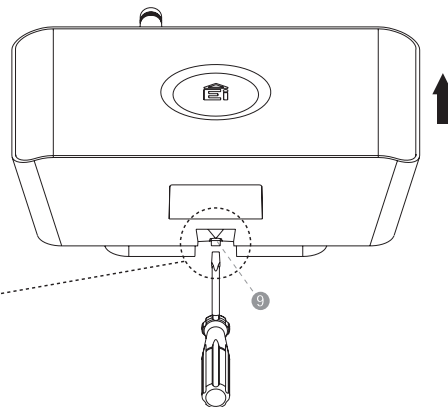
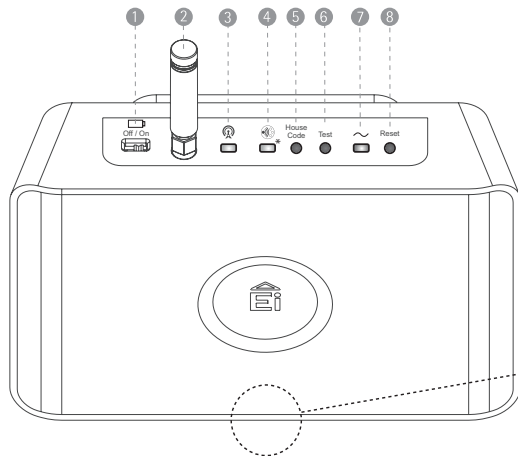

1	On / Off battery switch	2	Antenna
3	Cellular network LED (Amber)	4	House Code mode LED*
5	House Code button	6	Test button
7	Power LED (Green)	8	Reset button
9	Removal slot		

To unclip the Gateway from the mounting plate, insert a screw driver in to the slot shown above and push the Gateway upwards

* Protocol	House Code mode	Successful House Coding
RadioLINK	<input type="checkbox"/> Flashing Blue	N/A
RadioLINK Connect	<input type="checkbox"/> Flashing Purple	<input type="checkbox"/> Flashing Green

3. Technical Specifications

Supply Voltage:	230V AC, 50Hz
Battery back-up:	Rechargeable battery
Power consumption:	40mA
RF frequency:	RadioLINK: 868.499MHz (1% duty cycle) RadioLINK Connect: 868.2MHz (1% duty cycle)
RF power:	≤ 14dBm
RF Range:	>100 Metres in free air ¹
RF Protocol type:	Mesh/Star architecture depending on RF device
RF Protocol:	RadioLINK Connect with RadioLINK fallback
RF System size ²:	In RadioLINK systems: up to 12 RF devices In RadioLINK Connect systems: up to 32 RF devices
Receiver category:	2
Data upload:	via cellular network (Roaming SIM card supplied)
Modem:	4G
Data storage:	Cloud based
Indicators:	Green LED - Power Purple/Blue LED - House Code mode Amber LED - Cellular communication

Normal Operating and

Storage Temperature Range: -10° to 40°C ³

Normal Operating and

Storage Humidity Range: 15% to 95% Relative Humidity ³ (non-condensing)

Approvals: Compliant with Radio Equipment Directive 2014/53/EU, KM 735628, Internet of Things (IoT)

1. Obstructions of any sort will result in a reduction in range from the free space specification. The range may vary depending on installation.
2. Please contact us for further advice if additional RF devices are required.
3. Temperature and Humidity conditions are for normal operation and storage. Units will function outside these ranges as required by the specific product Standards. Extended exposure to conditions outside these ranges can reduce product life. For advice on prolonged operation outside these ranges consult the manufacturer.

4. Important Safety Instructions

WARNING: Mains operated devices should be installed by a qualified electrician in accordance with the local appropriate Regulations for Electrical Installations. Failure to install the Gateway correctly may expose the user to shock or fire hazards and damage the device.

ATTENTION: This device must be continuously powered 24 hours a day so it is important that it is not on a circuit that can be turned off by a switch.

WARNING: This device should only be installed in a location where an all-pole mains switch in accordance with Annex L of EN62368-1 is incorporated in the electrical installation of the building. As the device is permanently connected to mains supply, the appropriate disconnect device shall be provided as part of the building installation.

ATTENTION: This device must not be connected when the house wiring insulation is being checked with high voltages. i.e. Do not use a high voltage insulation tester on the device.

ATTENTION: Light Dimmer Circuits - the Gateway must not be powered from a light dimmer circuit.

5. Locating Your Gateway

To identify a suitable location for the installation of your Gateway, we recommend you first perform a short cellular survey as follows:

1) Move the Battery Switch (see figure 1) to the "On" position. (DO NOT CONNECT TO THE MAINS SUPPLY at this stage).

ATTENTION: Do not leave your Gateway on battery power only for longer than 72 hours.

2) Screw the Antenna (located in the bag supplied) on, by rotating the gold nut clockwise and ensuring it is tightened fully in place by hand. Ensure while performing the survey that you hold the Gateway with the Antenna in the vertical orientation.

3) Using a small screwdriver or pen, press the Test button.

4) Count the Cellular network LED flashes.

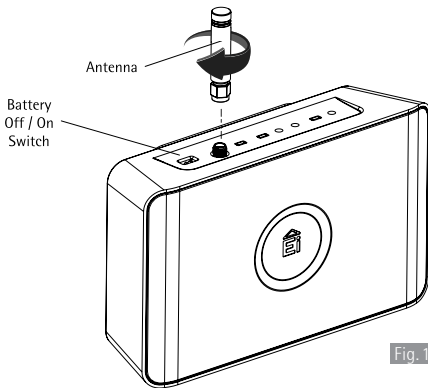

Fig. 1

Number of Flashes	Signal Strength
4	Best location
3	Strong and stable signal
2	Acceptable
1	Avoid this location
0	Do not install here

If your Gateway is indicating a poor signal strength, we recommend you move to a location that provides you with the best signal strength.

It is also equally important that the Gateway communicates with the RF devices installed in the dwelling. The number of walls, ceilings and metal objects in the signal path will reduce the strength of the RF signals.

Do not mount your Gateway in a steel box or close to large metal objects such as boilers, as this will reduce your cellular network signal strength and will affect RF communication.

The Gateway is not waterproof and must not be exposed to dripping or splashing. Do not locate the Gateway in a wet room, bathroom, shower room, etc...

6. Installation

WARNING: To prevent injury, this device must be securely attached to the wall in accordance with the installation instructions.

Fig.2

* Important *
Note plate
orientation

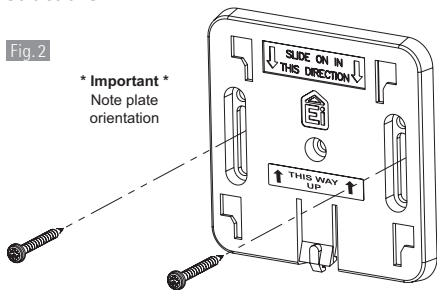

Please ensure your Gateway is mounted with the Antenna in the vertical orientation. It is recommended that the Gateway is mounted at least 2m from floor level.

1. Fix the mounting bracket to the wall with the screws provided (see figure 2).

IMPORTANT - Make sure the mounting plate is positioned on the wall in the correct orientation before fixing (see figure 2).

2. Disconnect the AC mains supply from the circuit that is going to be used.

3. Wire the Gateway 2 core cable into an un-switched spur. There is a cable channel in the rear of the Gateway that can be used to run the power cable left or right of the Gateway (see figure 3). Do not coil excess cable around the Gateway and keep the cabling away from the antenna.

Fig.3

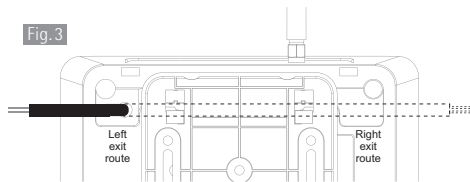

L : Live - Brown and N : Neutral - Blue

WARNING: *Wiring must be installed in compliance with local regulations.*

- Slide the Gateway onto the mounting plate.
- Connect the mains power to the circuit used.
- Check that the Power LED on the Gateway is on.

On power up, the House Code mode LED and Cellular network LED will also flash for a short period (<1 min). On stand by, only the Power LED is on.

Gateway LED Indicator Table

Mode	Action	Power LED	House code mode LED	Cellular network LED
Cellular network signal survey	Press Test button	-	-	Flashing
Power up		ON	Rapid Flashing	3 slow Flashes
Standby		ON	-	-
House Coding		ON	Flashes	-
Cellular communication		ON	-	ON
Battery OFF with Mains supply ON*		ON	ON	ON

***ATTENTION:** *Please ensure that the battery switch is in the "ON" position. Failure to carry out this step will result in no battery backup capability if power is lost to the Gateway.*

7. Gateway System Set Up

Do not start the system set up until the Gateway is in Standby mode.

To set up a Gateway system, simply follow the steps in the SmartLINK® App available to download from the Google Play or iTunes app store.



If you do not have log-in details for the SmartLINK App and you will be managing the system, you will need to register by scanning the QR code or email:

customerservice@eielectronics.ie

If you are installing the system and someone else will be managing it, **they will need to complete the registration and create an Installer Account for you.**

If you have a log-in but the client you are installing for is not listed in the SmartLINK App, please contact the client directly to request they create an Installer Account for you.

For any queries please contact customerservice@eielectronics.ie or call 061 471277.

8. Testing

Once the system has been installed and set up, a test should be performed to validate it is functioning correctly as follows:

- 1) Press and hold the test button on an Alarm or temporarily remove for example an Environmental Sensor from its base if no Alarms are present. This will generate an event.
- 2) Check that the Cellular Network LED on the Gateway lights up, indicating the event information has been sent to the Cloud server.
- 3) On your phone SmartLINK® App, select "View Installations".
- 4) Select the system you are testing.
- 5) Select the unit you have tested.

- 6) Under the Events tab, "Button Test" or "Head Removed" will be listed with the corresponding date and time; confirming that the event information is stored on the Cloud server.
- 7) If an Environmental Sensor was removed to generate the event, refit the Environmental Sensor and ensure that a 'Power Up' event is seen under the Events tab for the unit.

9. Troubleshooting

Incorrect number of flashes on the Gateway during the House Coding process	If you are unable to house code some devices to the Gateway, you may need to move the Gateway or position another Alarm to act as a "repeater" between the device(s) which is (are) not communicating with the Gateway to shorten the path and/or by-pass an obstacle which is blocking the RF signal.
Factory Reset	Sometimes in order to resolve an RF communication issue it may be necessary to reset (factory reset) and House Code all the RF devices again. To reset the Gateway, press and hold the House Code button until the House Code mode LED starts to flash. Release immediately.
House Code error message on SmartLINK® App when uploading	Press "Retry" to upload again.
Check internet connection message on SmartLINK® App	This means that your phone has no mobile service. Move to an area where your mobile service is restored.

10. Guarantee

If, within the guarantee period, your Gateway fails to work after you have carefully read and followed all the instructions and installed the Gateway accordingly, then contact Ei Customer Service using the details below:

e-mail: customerservice@eielectronics.ie

Tel: 061 471277

If you are advised to return your Gateway, please ensure that the device is placed in a padded box, with the proof of purchase and a note stating the nature of the fault.

Ei Electronics guarantees this Gateway for five years from the date of purchase against any defects that are due to faulty materials or workmanship. If this device should become defective within the guarantee period, we shall at our discretion repair or replace the faulty unit.

This guarantee only applies to normal conditions of use and service and does not include damage resulting from accident, neglect, misuse, unauthorised dismantling, or contamination howsoever caused. This guarantee excludes incidental and consequential damage.

This guarantee does not apply to any product that has been modified in any way by a third party or has been fitted with a third party element.

Do not interfere with the gateway or attempt to tamper with it. This will invalidate the guarantee but more importantly may expose the user to shock or fire hazards.

This guarantee is in addition to your statutory rights as a consumer.



Hereby, Ei Electronics declares that this Ei1000G Gateway is in compliance with the essential requirements and other relevant provisions of Directive 2014/53/EU. The Declaration of Conformity may be consulted at www.eielectronics.com/compliance

The crossed out wheelie bin symbol that is on your product indicates that this product should not be disposed of via the normal household waste stream. Proper disposal will prevent possible harm to the environment or to human health. When disposing of this product please separate it from other waste streams to ensure that it can be recycled in an environmentally sound manner. For more details on collection and proper disposal, please contact your local government office or the retailer where you purchased this product.





Contact Us

Ei Electronics

Shannon Industrial Estate,
Shannon, V14 H020, Co. Clare, Ireland.

Telephone: +353 (0)61 471277

www.eielectronics.com